

The Effect of Cultural Components on Organizational Performance in Startups

Soraya Alipour*

Master Student, Electronic
Department, Entrepreneurship
Management, Tehran Branch, Islamic
Azad University, Tehran, Iran.

*Corresponding Author:

✉ s.alipour@gmail.com

Received: 20 September, 2020

Accepted: 30 October, 2020

Published: 25 November, 2020

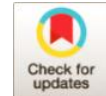

ABSTRACT

The main purpose of this study was to investigate the effect of cultural components on organizational performance in startups. For this purpose, by literature reviewing and theoretical foundations which were derived from independent and dependent variables, the research model was designed. The independent variable of research included cultural components including the dimensions of diversity and breadth, trust and messaging and dependent variable of research included organizational performance in startups. According to the designed model, a questionnaire was distributed among the statistical sample that included all managers of startups in Tehran City. In this regard, 168 questionnaires were distributed by simple random sampling method and by collecting it, the data were analyzed using the structural equation modeling and Amos software. According to the results, all research hypotheses in line with the impact of organizational culture on the dimensions of diversity and breadth, trust and easy communication in startups on organizational performance in startups were confirmed. Also, according to the analysis of the relationship between independent and dependent indices, the variables of messaging, diversity, breadth and trust dimensions showed the highest relationship with 0.86, 0.83 and 0.82, respectively.

Keywords: Cultural components, Organizational performance, Startups

Introduction

Organizational culture is a process that most companies use to guide and advance their programs and activities with a long-term horizon and in order to achieve their goals and fulfill their organizational missions. If the strategy of organizational culture is properly formulated and implemented correctly and in a timely manner, the path of excellence and the realization of the organization's dreams will be realized. Strategic planning, by examining the external and internal environment of the organization, identifies the environmental opportunities and threats and internal strengths and weaknesses, and considering the mission and long-term goals of the organization and to achieve these goals, choose strategic strategies among the strategic options. Nowadays, it seems that organizations face rapid changes and developments and must plan and direct their activities in such a way that

they succeed in a competitive environment and continue to live according to the concept of the program. Strategic planning, this requires the use of this type of planning [1].

Businesses, on the other hand, have begun to use organizational culture as a way to help connect employees, customers to obtain information and help. Business companies use corporate culture services to support their products or customer service as a new trend [2]. In addition to the corporate culture used by companies to provide employee or customer service, the online corporate culture attracts online advertising from retailers and other companies. Placing online ads on corporate culture websites will benefit from the high traffic volume of potential customers. Most online businesses use multiple revenue models, and almost all corporate culture websites use advertising revenue models, subscription fees, and link fees. But the main source of income for online organizational culture is



advertising and link fees. The right to subscribe has a smaller share in their income [3].

Organizational culture has a very important impact on how users communicate. Today, users are looking to research and share their information. The results show that when the most users are not involved in corporate culture, those who trade with their friends through corporate culture usually reap significant benefits in the form of higher user satisfaction. Users join these networks, publish and support their profiles, and create an organizational culture with their friends. The result of this social organizational culture is a document that shows the level and amount of trust created between related users. Many people believe that increasing online markets with the characteristics of organizational culture should improve trust between transaction parties and user satisfaction.

Traditional online marketplace customers typically trade with complete strangers, thus making them vulnerable to fraudsters. While a social market combines the characteristics of organizational culture with the online shopping community and allows customers to buy from friends or friends of their friends [4].

Service-based economy, as an emerging phenomenon in the field of e-commerce, has made the position of the service sector in the economy important, as well as attention to how to improve the level of service quality. Today's organizations have to pay attention to the quality of their products and services in order to survive, so that they can satisfy their current customers and attract new ones and guarantee and increase their revenue sources. Since the discussion of service marketing is an important category of marketing, and due to the intangible nature of services, the role of creating a good relationship and paying more attention to quality organizational culture with the customer by service providers is an undeniable fact [5].

Retailers, organizations, and manufacturers around the world use corporate culture for marketing. If organizational culture is combined with effective traditional marketing methods, they can be an effective tool for establishing communication and maintaining relationships with the donors. Today, a large population of the country has access to organizational culture on a daily basis and directly affects how marketers use organizational culture. Revenue growth in organizations depends to a large extent on the relationship between the organization and the general public. The relationship between the organization and the general public not only leads to more donations but also continues to buy them. Despite this focus on communication, researchers are studying the application of organizational culture like Facebook, Twitter, Instagram, Telegram, and WhatsApp, between the organization and its stakeholders. Even organizations that use the traditional face-to-face

approach to sale, emphasize the effectiveness of technology in changing relationships and maintaining them. Of course, there is a research gap between the use of organizational culture on strengthening existing relationships with customers through its impact on the annual financial income of the organization [6]. For this purpose, in the present study, we seek to determine whether the cultural components affect organizational performance in startups or not.

Literature review

Customer satisfaction is a result that is obtained by a customer's pre-purchase comparison of expected performance with actual perceived performance and cost paid [7].

Jamal and Nasser [8] define customer satisfaction as a customer's feeling or attitude towards a product or service after using it. Two researchers state that customer satisfaction is the main result of marketer activity which works as a link between different stages of consumer buying behavior. For example, if customers are satisfied with a particular service, they are more likely to repeat their purchase. Satisfied customers are also more likely to talk about their experiences with the others, resulting in word-of-mouth advertising. In the face of dissatisfied customers, they are likely to cut ties with the company and engage in negative word-of-mouth advertising. In addition, behaviors such as repeat purchases and word-of-mouth advertising directly affect a company's survival and profitability [8].

Kim and Ko [4] define the social media as a technology to facilitate organizational culture and interactions, and that it enables collaboration between negotiators. Social media is a type of electronic communication that enables interaction between users, no matter a personal relationship with another person or a personal relationship with the organization. People can record posts or blogs from the moment they experience whether they share their feelings or dissatisfaction with a product anywhere in the world that has access to a laptop or phone and wireless. Beyond that, social media is a phenomenon as account holders in these programs shape this organizational culture (friends, followers, e-commerce) and prepare it for social sharing [4]. The phenomenon of being new as well as studying social media is still a repetitive step. The newness of social media means that many theories have not been extracted from the initial researches; ones related to the methods and reasons why people use sites like Facebook, Twitter. Non-profit organizations have generally not used the marketing and social media tools available on social media. Before using social media, it is important to know what organizations use social media for. An organization should refer to the better

performance of the other organizations and examine them as well [9].

In general, organizational culture as the social structures is made of nodes that are usually connected to individuals or organizations by one or more specific types of communication. Organizational culture connects people with all different interests. One of the expanded areas in the use of these networks is the corporation environments. Social researchers, for many years, have been interested in the fundamental question of how inclinations, behaviors, and innovations spread through organizational culture.

Organizational culture models are more descriptive than predictive and are built on very large levels and generally with a small number of global parameters and are not suitable for realistic prediction of future behaviors. Experimental studies, as well as the fact that there was little information about nodes, we lacked a lot of information. Fortunately, the growth and increase changed this tragedy [10].

Today, huge amounts of information are available on social networks, blogs, information sharing sites, and corporate culture sites, as well as online games. These networks generally have tens of thousands to millions of nodes and often contain large amounts of enough information that can help the marketing of companies and organizations. In this study we attempt to examine its impact.

Felix et al. [11] found out this issue. They conducted 40 interviews with staff at various levels of the American Red Cross. At the time of this study, the American Red Cross organizational culture was used solely as an information and news tool. It was very rare for anyone to be accountable in the organizational culture of that organization. There was generally no two-way interaction. Many government departments use organizational culture, but there is little evidence that interaction is possible.

Cheng et al. [12] in a global analysis comparing the corporate culture of American and Chinese companies concluded that no real dialogue takes place. Companies in both countries often submitted content that demonstrated openness and transparency, but companies rarely responded to user-generated content. Sending information about new or current products and services alone does not involve two-way interaction with the audience, even if a question was asked to start a conversation, companies would not respond to comments made by users.

Ashley and Tuten [13] in their study on 500 companies concluded that the most companies use at least one type of information and most of them use Twitter. They also stressed the need to develop a strategy for encouraging the customers or the other stakeholders to engage them in existing information. In this study, one of the factors involved in the inclusion of effective content is consistently identified. This can be done by

interacting between people involved in the organizational culture with product development teams or senior managers.

Chang et al. [14] in their research stated that one of the simplest suggestions for involving people in the organizational culture of companies or organizations was to find their information page easily. It is done from the companies' websites. They can easily find the link to the information and become a member. Once the organization has successfully encouraged stakeholders to the information, the organization's site can become a valuable public relations tool. However, some organizations do not take advantage of the opportunities provided by organizational culture for two-way interaction.

Berthon et al. [15] in their research stated that organizational culture can be attractive in terms of marketing, creating relationships and data collection tools for organizations, but the goals and the target community should be clearly defined. The study also showed that organizations need to find ways to encourage users who are in direct contact with employees via mobile or email to use information as well. Many organizations use their information to take advantage. They control their audiences in a specific geographic area. These organizations also use existing information tools such as Facebook and Twitter to trade.

De Vries et al. [16] in their research stated that the organizational culture has changed the marketing of companies and organizations. They acknowledged that the effects of this paradigm of communication between the organization and the general public need further study. Levenshus says that there is a need to study on how the supporters of the organization cooperate online and how they look at their relationship with the organization. If there is a connection between the relationship of organizational culture and more continuous sales, it will send a message to organizations that they need to allocate human and financial resources to make stronger use of organizational culture.

Akar and Topçu [17] created a social media page in a case study at Michigan State University. The purpose of this internal information was to gather information from Michigan residents to meet their needs assessment requirements in 2010. It is necessary for organizations to launch a propaganda campaign to promote their presence in social networks. Another feature was that the University of Michigan recruited members to use their websites outside of campus.

In the early 2010s, Hoffman and Fodor [18] stressed the need for further research on the effects and the other new media and the relationship between the organization and the general public. Organizational culture is a new phenomenon in the non-profit

organization. Unfortunately, not much researches have been done in this field.

A study conducted by Razzaghi [19] states that social media has created a huge change in the field of business and marketing. Therefore, this article deals with topics such as social media marketing and its impact on business, basic principles in media marketing, the relationship between social networks, brand awareness, innovation and creativity. The purpose of this study is to investigate the effect of innovation and creativity on brand awareness by considering the mediator variable of social media marketing. The research method is applied in terms of purpose and descriptive-survey method. The statistical population of the study includes managers and senior experts in the sales department of pipe and fittings industries in Tehran province, whose number is 284 people. A questionnaire was used to collect the data. To evaluate the questionnaire, a five-choice Likert scale was used on the continuum, I strongly agree with strongly disagree. The reliability of the research questionnaire in each component was assessed through Cronbach's alpha and in all cases was confirmed at an appropriate level. In order to determine the validity of the questionnaire, the opinions of experts have been used. In this research, regression tests and structural equation methods have been used to analyze the obtained data. SPSS and LISREL software were used for data analysis. In examining the first hypothesis of the research, it was found that innovation and creativity have a positive effect on brand awareness. Examining the second hypothesis of the research, it was found that the social media marketing index has a mediating role in the relationship between innovation and creativity and brand awareness.

In a study conducted by Pourghorban et al. [20], it is stated that technology gives the customer the ability to research, label and critique products. Therefore, many companies today had pages in the organizational culture to provide information about their products and get the necessary answers from customers. In this article, the effect of social media on customer performance was examined. 116 respondents or volunteers and univariate and two-variable analysis were used. After analysis, the profiles of customers who use the organizational culture, were created, and after performing statistical analysis and online platform analysis of the host questionnaire, the real effects of social media on changes in customer performance were examined.

In a study conducted by Ebrahimi and Bagheri [21], it has been stated that in today's competitive world, the success of companies is in maintaining and communicating with the customer and e-business can meet the explicit and implicit needs of customers. It can be useful for several reasons. For example, it provides easy access to products that may not be

accessible without them. In addition, e-commerce is an easy way to conduct exchanges, and although it is sometimes more vulnerable than its traditional form, it can largely meet the needs and requirements of consumers. E-commerce is a new way of doing business electronically using networks. In this method, the process of buying and selling or exchanging products, services and information is done through computer and telecommunication networks. The present study aimed to investigate the factors affecting purchasing through organizational culture. The present study was quantitatively applied in terms of purpose and descriptive in terms of research method. The results of literature and research related to the research topic confirmed that factors such as market environment, product features, acquaintances and advertising on the purchase of organizational culture affect the purchase.

Moradi and Hamidi [22] in their research stated that web-based social media has become very popular as a medium for disseminating information and connecting like-minded people. Public access to these networks has also created new opportunities for companies and governments with the ability to share ideas, thoughts, information, and experiences. In addition to people connecting to their friends and family using these networks, governments and companies have begun to use these networks to provide services to their customers. However, the success of such efforts depends on the level of trust that media members have in each other as well as in service providers. Trust is a fundamental principle in any business. Because there is no physical interaction between buyer and seller in social commerce, customer trust is a key barrier to social commerce and is very important to marketers. Therefore, trust is an essential and important element in a successful communication, in this seminar, we first examine the literature on social media trust and the existing definitions of trust in this field. We then review recent work that addresses three important aspects of social trust, including the collection of trust information, the assessment of trust, and the dissemination of trust. Finally, it compares the work and identifies the opposites and areas for further researches.

Theoretical framework of research

No research has been done on the effect of cultural components on organizational performance for startups in the country. For this purpose, the present study, as a pioneering research in this field, attempts to investigate this issue in relation to the impact of organizational culture. The conceptual model of the present study is taken from the one done by Carol et al. (2016). Also, considering that it has not been done any study on the effect of cultural components on

organizational performance for startups in the country so far, for this purpose, the present study as a research pioneer in this field, has sought to investigate this issue

in relation to the impact of organizational culture. the conceptual model of the study is presented in Figure 1.

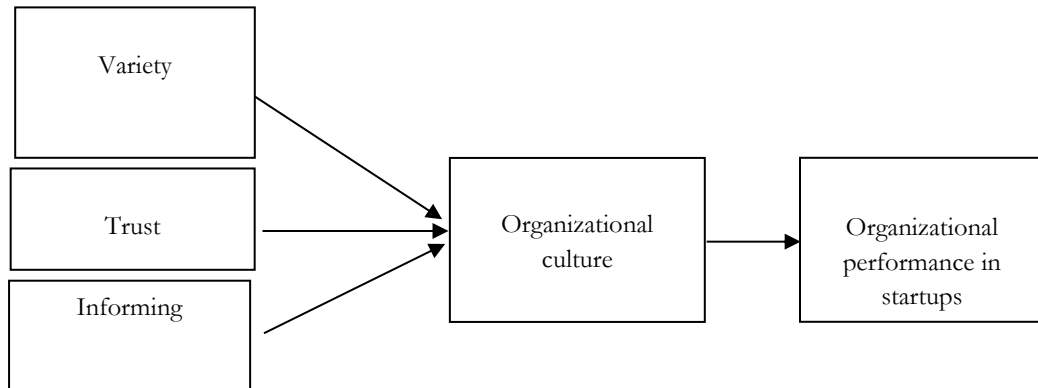

Figure 1. Conceptual model of research.

Data analysis

According to the studies conducted in the previous sections, which examined each of the dimensions and

fitting of the questionnaire, in this section, the general structure of the research is reviewed.

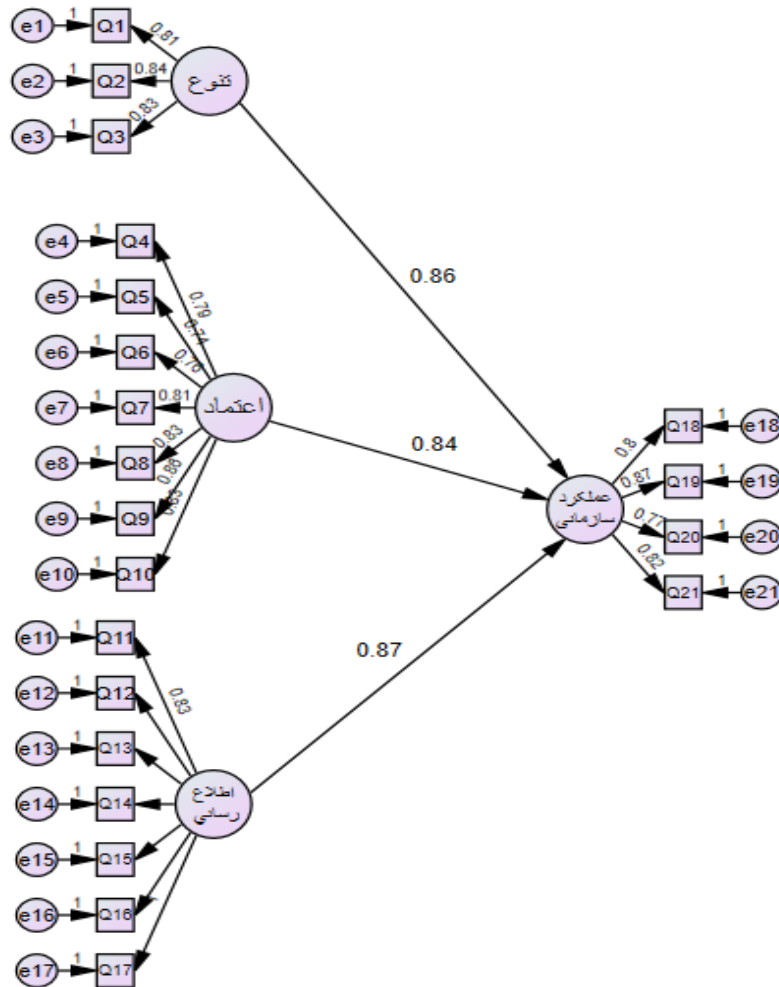

Figure 2. Structural equation model (standard mode).

To check the model fitting, the results can be observed in the following Table.

Table 1
Studying the general fitting of structural equations.

Parameter name	Value	Limit
Chi-square ratio to degree of freedom	1.251	Less than 3
Root Mean Square Error of Approximation (RMSEA)	0.001	Less than 0.05
Comparative Fit Index (CFI)	0.968	Greater than 0.9
Goodness of fit index (GFI)	0.988	Greater than 0.8
Adjusted goodness of fit index (AGFI)	0.985	Greater than 0.8

Examining research hypotheses

The main hypothesis

Cultural components affect organizational performance in startups.

Sub-hypotheses of the research also include:

- Diversity and breadth affect the organizational performance in startups.

- Trust affects organizational performance in startups.
- Messaging affects the organizational performance of startups.

In this section, according to the first main hypothesis, the results show a significant relationship between information and organizational performance in startups, the results are presented in Table 2.

Table 2
Correlation between information and organizational performance.

	Information	Organizational performance
Pearson correlation	1	0/77
significance level		0.000
Pearson correlation	0/77	1
significance level	0.000	

Sub-Hypotheses

According to the results of Table 3, the significance level is less than 0.05, indicating a significant

relationship between diversity, extent and organizational performance in this area.

Table 3
Correlation between diversity, extent and organizational performance.

	Variety and extent	Organizational performance
Pearson correlation	1	0.83
significance level		0.002
Pearson correlation	0.83	1
significance level	0.002	

According to the results of Table 4, the significance level is less than 0.05 that indicates a significant

relationship between trust and organizational performance in this field.

Table 4
Correlation between trust and organizational performance.

	Trust	Organizational performance
Pearson correlation	1	0/82
significance level		0.001
Organizational Performance	Pearson correlation	0/82
		1

According to the results of Table 5, the level of significance is less than 0.05, indicating a significant

relationship between easy communication and organizational performance in startups in this field.

Table 5
Correlation between information and organizational performance.

		Easy communication	Organizational performance in startups
	Pearson correlation	1	0/86
	significance level		0.025
Organizational performance in startups	Pearson correlation	0/86	1

Conclusion and recommendations

One of the unique features of today's world is the organizational culture. The spread of culture has made new organizations so distinct from previous societies that the new age has been called the "age of culture." In such a society, the media and the mass media play an important role as a key element in organizational culture. Among all new tools and techniques, the mass media have the greatest cultural impact on the behavior of society. These media are influential in the emergence of new habits, changes in beliefs, moods and human behavior. Communication networks are among the new phenomena that have emerged as a result of the integration of various communication technologies in recent years. Also, in today's competitive world, the services provided by passenger services are becoming more and more similar to each other due to the tourism boom and the direction of services in this field, and it is difficult to surprise the customer by providing completely innovative service in the long run. Because the most innovative services are quickly imitated by competitors and marketed.

The main purpose of this study was to investigate the effect of cultural components on organizational performance in startups. For this purpose, by reviewing the literature and theoretical foundations of the research model, which were derived from independent and dependent research variables; the independent research included variable of cultural components such as the dimensions of diversity and extent, trust and easy communication and dependent variables of the research included organizational performance in startups. According to the designed model, a questionnaire was distributed among the statistical sample that included all managers of startups in Tehran City. In this regard, 168 questionnaires were distributed by simple random sampling method and by collecting it, the data were analyzed using structural equation modeling and Amos software. According to the results, all research hypotheses in line with the impact of organizational culture in dimensions of diversity and extent, trust and easy communication in startups on organizational performance in startups, were confirmed. Also, according to the analysis of the relationship between independent and dependent indices, the variable dimension of easy communication, diversity, extent and trust showed the highest relationship level of 0.86, 0.83 and 0.82, respectively.

According to the main hypothesis of the research, which indicates the confirmation of cultural components on organizational performance in startups, the correlation coefficient was equal to 0.77, which according to the allowable level of significance obtained in this section, this hypothesis was confirmed. The results of this section are in line with the researches done by Felix et al. [11], Ashley and Tutten [13], Chang et al. [14] and Razzeghi [19].

According to the results of the first sub-hypothesis, which shows the confirmation of the relationship between diversity and extent on organizational performance in startups, with a correlation coefficient of 0.83 and a significance level of less than 0.05, was confirmed. The results of this section are in line with the researches done by Ashley and Tutankhamun [13], Chang et al. [14] and Razzeghi [19].

According to the results of the second sub-hypothesis, which shows the confirmation of the relationship between trust and organizational performance in startups, the correlation coefficient was 0.82 and the significance level was less than 0.05, which indicates the confirmation of the relationship in this section. The results of this section are in line with the researches done by Chan and Gillett [10] and Kim and Ko [4].

According to the results of the third sub-hypothesis, which shows the confirmation of the relationship between information and organizational performance in startups, the impact factor was 0.86 and the significance level was smaller than 0.05, which indicates the confirmation of the relationship in this section. According to the results obtained in this section, the results are in line with the research the researches done by Chan and Gillette [10], Ashley and Tutten [13], and Chang et al. [14].

According to the results of the present study, the following suggestions can be made.

1. According to the first sub-hypothesis, which refers to the confirmation of the relationship between diversity and extent on organizational performance in startups, suggestions such as providing diverse, multiple and different information about the organization, creating diversity of views in the virtual social network in order to increase the power of choice in relation to the organization, the possibility of expressing ideas freely and familiarity with the ideas, thoughts and tastes of people in the organization, were considered.

2. In connection with the second hypothesis, which refers to the confirmation of the relationship between trust and organizational performance in startups, it can be recommended things such as increasing emotions, the possibility of creating physical bases, the possibility of exchanging information and response systems, and managing the relationship with charity during the day.

3. In connection with the third hypothesis of the research, which refers to the confirmation of the relationship between information and organizational performance in startups, the creation of a forum for exchanging opinions, the use of group networks in the telegram, holding meetings to familiarity with different ideas, can be recommended.

Suggestions for future researches include:

- Comparison of the results of present study with foreign organizations.
- Using the quality performance enhancement approach to identify the most important factors affecting organizational performance

References

1. Brady MK, Robertson CJ. Searching for a consensus on the antecedent rol of service quality and satisfaction: an exploratory cross-nationalstudy. *J Bus Res.* 2001; 53-60.
2. Wang Y, Hsiao SH, Yang Z, Hajli N. The impact of sellers' social influence on the co-creation of innovation with customers and brand awareness in online communities. *Indust Market Manag.* 2016; 54: 56-70.
3. Agnihotri R, Gabler CB, Itani OS, Jaramillo F, Krush MT. Salesperson ambidexterity and customer satisfaction: examining the role of customer demandingness, adaptive selling, and role conflict. *J Pers Sell Sal Manag.* 2017; 37(1): 27-41.
4. Kim AJ, Ko E. Do social media marketing activities enhance customer equity? An empirical study of luxury fashion brand. *J Bus Res.* 2012; 65(10): 1480-1486.
5. Samadi M, Hajipour B, Hajizadeh H. Inadequacy in service delivery, culture strategy of service revitalization organizations and their impact on consumer behavior. *J Bus Manag.* 2008; 1(1): 71-86.
6. Klier J, Klier M, Müller AL, Rauch C. The impact of self-service technologies-towards an economic decision model and its application at the German Federal Employment Agency. *J Decis Syst.* 2016; 25(2): 151-172.
7. Beerli A, Martin JD, Quintana A. A model of customer loyalty in the retail basnking market. *Eur J Market.* 2014; 38(1): 2.
8. Jamal A, Naser K. Customer satisfaction and retail banking: an assessment of some of the key antecedents of customer satisfaction in retail banking. *Eur J Market.* 2002; 20(4): 146-160.
9. Naseri S, Faghih Mirzaei S, Salman Khaksar A. Identification and ranking of positive factors affecting customer satisfaction in the field of social network

services. 2nd National Computer Conference, Sanandaj, Sama Technical and Vocational College, Sanandaj. 2013.

10. Chan NL, Guillet BD. Investigation of social media marketing: how does the hotel industry in Hong Kong perform in marketing on social media websites. *J Trav Tourism Market.* 2011; 28(4): 345-368.

11. Felix R, Rauschnabel PA, Hinsch C. Elements of strategic social media marketing: A holistic framework. *J Bus Res.* 2017; 70: 118-126.

12. Cheng M, Wong IA, Wearing S, McDonald M. Ecotourism social media initiatives in China. *J Sustain Tourism.* 2017; 25(3): 416-432.

13. Ashley C, Tuten T. Creative strategies in social media marketing: An exploratory study of branded social content and consumer engagement. *Psychol Market.* 2015; 32(1): 15-27.

14. Chang YT, Yu H, Lu HP. Persuasive messages, popularity cohesion, and message diffusion in social media marketing. *J Bus Res.* 2015; 68(4): 777-782.

15. Berthon PR, Pitt LF, Plangger K, Shapiro D. Marketing meets web 2.0, social media, and creative consumers: Implications for international marketing strategy. *Bus Horizon.* 2012; 55(3): 261-271.

16. De Vries L, Gensler S, Leeﬂang PS. Popularity of brand posts on brand fan pages: An investigation of the effects of social media marketing. *J Interact Market.* 2012; 26(2): 83-91.

17. Akar E, Topçu B. An examination of the factors influencing consumers' attitudes toward social media marketing. *J Inter Comm.* 2011; 10(1): 35-67.

18. Hoffman DL, Fodor M. Can you measure the ROI of your social media marketing? *MIT Sloan Manag Rev.* 2010; 52(1): 41.

19. Razzaghi M. The impact of innovation and creativity on brand awareness considering the social media marketing variable (Case study: Tehran pipe and fittings industries). Fourth International Conference on Environmental Planning and Management Biology, Tehran, Faculty of Environment, University of Tehran. 2017.

20. Pourghorban Saghti R, Mohammadzadeh B, Aghazadeh F. Social media and its effect on customer performance. International Conference on Computer Engineering and Information Technology, Tehran, Permanent Secretariat of the Conference. 2016.

21. Ebrahimi H, Bagheri M. A study of factors affecting the purchase of organizational culture (Facebook, Telegram, YouTube, etc.). World Conference on Management, Accounting Economics and Humanities at the Beginning of the Third Millennium, Shiraz, Green Industry Idea Market Research Company. 2016.

22. Moradi S, Hamidi H. Analysis of effective factors for trust in social media marketing. First International Conference on New Research Achievements in Management, Accounting and Economics, Tehran,

Office of the International Confederation of World
Inventors in Iran, Comprehensive University of

Applied Sciences Menu. 2016.

SJAMAO

Copyright: © 2020 The Author(s); This is an open-access article distributed under the terms of the Creative Commons Attribution License (<http://creativecommons.org/licenses/by/4.0>), which permits unrestricted use, distribution, and reproduction in any medium, provided the original work is properly cited.

Citation: Alipour S. The Effect of Cultural Components on Organizational Performance in Startups. *SJAMAO*, 2020; 2(4): 12-20.

<https://doi.org/10.47176/sjamao.2.4.12>